

INSTALLATION INSTRUCTIONS

Attaching an Automatic Opener

(For use with Steel Sandwich Residential Garage Doors)

Things to Know Before You Begin

Read the instructions completely before starting the installation of the automatic opener. Becoming familiar with the components before attaching the automatic opener to the door will reduce the installation time.



WARNING

In the interest of safety this symbol means **WARNING** or **CAUTION**. Personal injury and/or property damage may occur unless instructions are followed carefully.

Clopay[®] BUILDING PRODUCTS
A Griffon Company

Consumer Hotline
1-800-225-6729



WARNING

To avoid risk of strangulation or personal injury to children, you must remove the pull down rope when you install an automatic garage door opener.

IMPORTANT: When installing an automatic garage door operator, make sure to follow the manufacturer's installation and safety instructions carefully. **Remove the pull down rope and unlock or remove the lock.** If attaching an operator bracket to the wooden anchor pad, make sure the wood anchor pad is free of cracks and splits and is firmly attached to the wall. Always drill pilot holes before attaching lag screws.

To avoid damage to your door, you must reinforce the top section of the door in order to provide a mounting point for the opener to be attached. **Failure to reinforce the door as illustrated will void your Clopay Warranty.**

Step 1

Determining Operator Reinforcement Bracket Size

Measure the height of the top section. It will measure either 18", 19³/₈", or 21". For 18" and 19³/₈" door sections, the operator reinforcement bracket must be cut using a hacksaw as shown in Figure 1.

Be sure to wear a sturdy pair of gloves while cutting the bracket and watch for sharp edges. It may be necessary to file the edge of the bracket that was just cut.

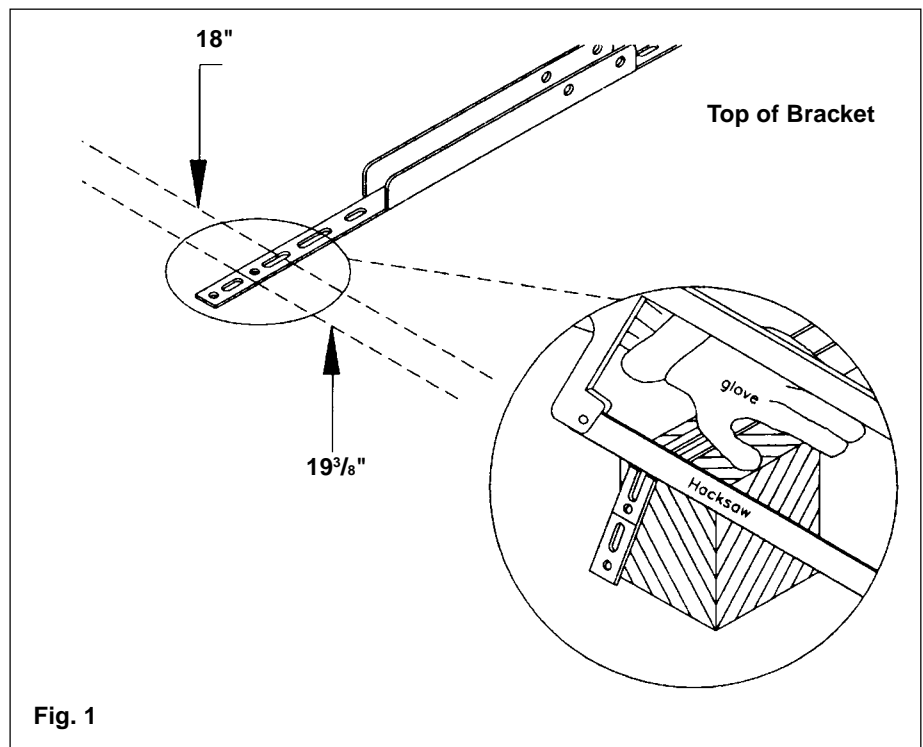

Fig. 1

Step 2

Attachment of Operator Reinforcement Bracket

The Operator Reinforcement Bracket fastens to the reinforcing plates which are built into the door (not visible). These plates will be located directly under the pre-punched holes. Proper attachment requires the use of #14 x 5/8" sheet metal screws and at least two reinforcing plates.

IMPORTANT: Use only the pre-punched holes in reinforcing the top section as improper fastener location may result in damage to the door or operator.

Figures 2 - 5 show the installation of the Operator Reinforcement Bracket. Each illustration corresponds to specific door width.

Note: All horizontal angle is attached with #14 x 5/8" sheet metal screws at the reinforcement back-up plate locations.

Torsion spring doors (Fig. 3)

A) Install opener arm to one of the operator reinforcement brackets. It is necessary to mount the operator off center of the door, to align with the operator reinforcement bracket. **OR B)** Install opener arm to the horizontal angle using the bracket provided with the operator or cut (2) 1" pieces of punched angle and mount on horizontal angle. (See Figures 3 & 6A for an example)

Extension spring doors

(Fig. 3) Install opener arm to the horizontal angle using the bracket provided with the operator or cut (2) 1" pieces of punched angle and mount on horizontal angle. (See Figures 3 & 6A for an example)

Note: Extension spring doors with openers, **must** attach the opener arm in the center of the door.

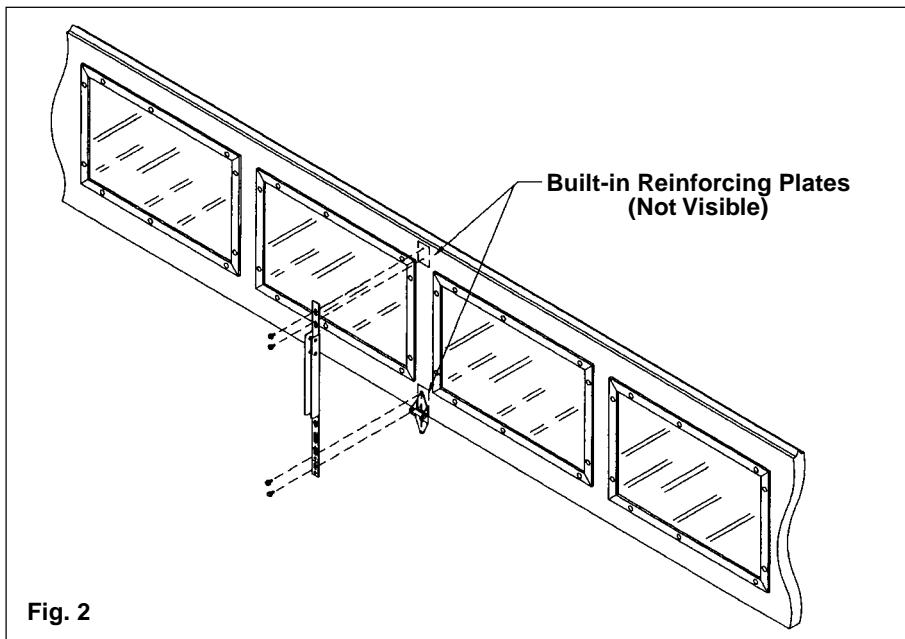

Fig. 2

8' Up to 9'10" Wide Doors Solid (without windows) or with windows

No horizontal angles required, (1) operator reinforcement bracket.

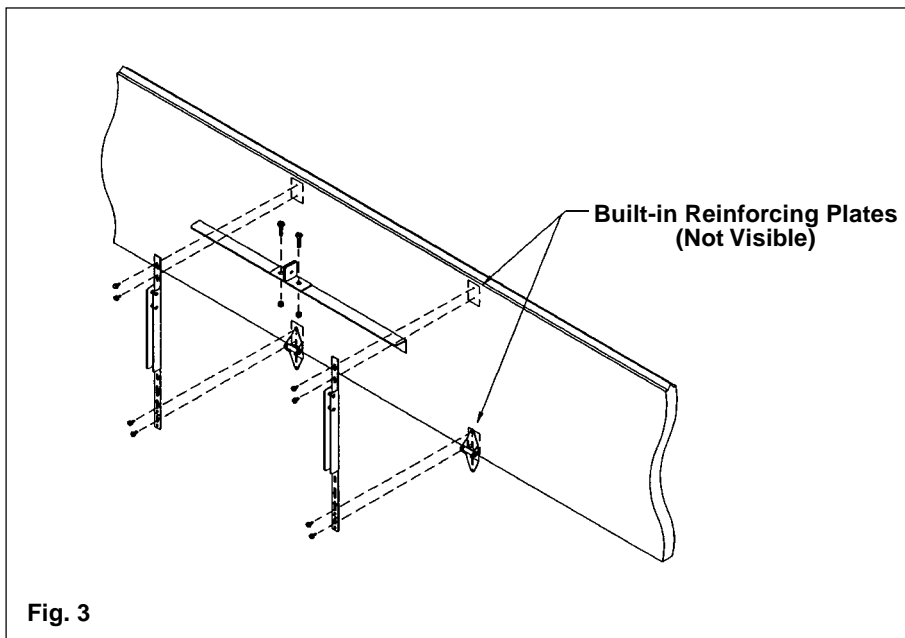

Fig. 3

10' Up to 15' Wide Doors

Solid (without windows) or with windows 10' - 11'10" & 14' - 15' Wide Doors

(1) 28" long horizontal angle required, (2) operator reinforcement brackets required.

Solid (without windows) or with windows 12' - 13'10" Wide Doors

(1) 56 1/2" long horizontal angle required, (2) operator reinforcement brackets required.

Torsion spring doors

(Fig. 4) Install opener arm to one of the operator reinforcement brackets. It will be necessary to mount the operator off center of door, to align with operator reinforcement bracket. **OR B)** Install opener arm to strut using bracket provided with operator or cut (2) 1" pieces of punched angle and mount on strut as shown with 1/4" x 20 hex bolts and nuts. (See Figures 4 & 6A for an example.)

Extension spring doors

(Fig. 4) Install opener arm to the strut using the bracket provided with operator or cut (2) 1" pieces of punched angle and mount on strut as shown with 1/4" x 20 hex bolts and nuts. (See Figures 4 & 6A for an example.)

Note: Extension spring doors with openers, **must** attach the opener arm in the center of the door.

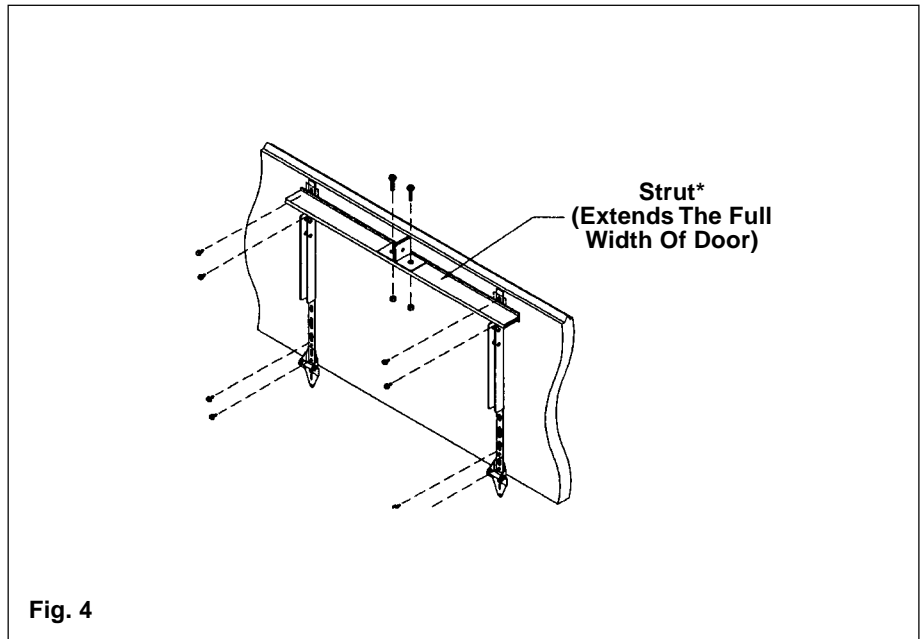

Fig. 4

15'2" to 15'10" Wide Doors – Strut Supplied Solid (without windows) or with Windows

*2" thick doors do not require strut

- (1) 28" long horizontal angle required
- (2) operator reinforcement brackets required.

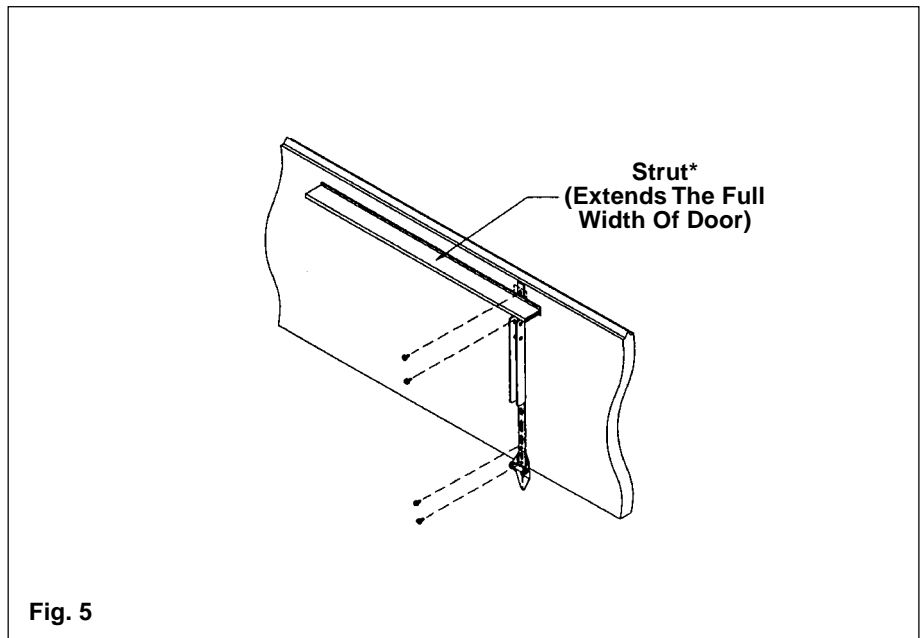

Fig. 5

16' up to 18'10" Wide Doors – Strut Supplied Solid (without windows) or with Windows

*2" thick doors do not require strut

- (1) operator reinforcement bracket required.

Step 3

Attachment of Opener Arm

Attach the opener arm of the automatic garage door opener to the Opener Reinforcement Bracket by sliding the clevis pin through either hole A or B, then through the hole on the opener arm and finally through the opposite hole A or B. Once the clevis pin is completely through, insert the cotter ring at the end of the clevis pin. See Figures 6 & 6A.

The opener arm should be attached roughly at the same height as the top rollers of the door. This is about 3" to 5" from the top of the door.

